

PRODUCT:

QUANTITY:

ITEM #:

## Designed Smart

- Designed to cook and hold pre-cooked foods from frozen state.
- Perfect for soups, chili, and other dishes that need a quick thaw during the cooking cycles and a gentle warming heat for serving.
- CW-2Ai model has unique “serpentine shaped” heating elements that evenly distribute heat throughout the unit.
- CW-1B utilizes a bottom mounted heating element and an aluminum transfer plate to provide superior heat.
- Provided with insulation to protect interior parts and countertops from heat build-up.
- CW-1B accepts an 11 qt. inset, or with adaptor, a 7 or 4 qt. inset.
- Both models are provided with knob guards.

## Built Solid

- Constructed with heavy-duty stainless steel for excellent durability.
- Inside liner made with stainless steel.
- Steel “element support” stabilizes heating elements and reflects heat toward food.

## Reliability backed by APW Wyott’s Warranty

- The CW-2Ai and CW-1B are backed by a 1-year Parts and Labor warranty.
- The CW-2Ai is included in our “Enhanced Warranty” service that replaces new units with certain product issues through the convenience of direct/factory shipments.

## Certified by the following agencies:



Intertek



Intertek



Model CW-2Ai Classic Cook & Serve



Model CW-1B Classic Cook & Serve

## APW Wyott Design Features

- Wet Usage 100°F to 212°F (38°C to 100°C) recommended.
- Heavy-duty stainless steel for long life.
- Easy to clean.
- Thermostatically controlled.
- Great for buffets, serving lines, back bars or back-of-the-house.
- Handles breakfast, lunch and dinner.
- Pans and insets not included.

See reverse side for product specifications.

PRODUCT:

QUANTITY:

ITEM #:

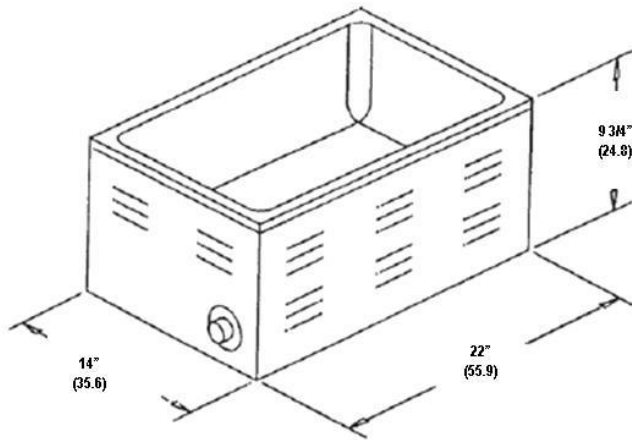

Model CWi-2A Classic Cook & Serve

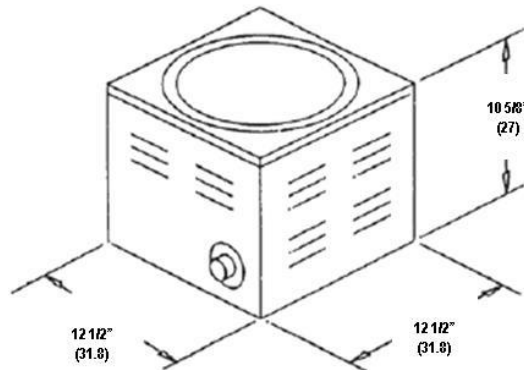

Model CW-1B Classic Cook & Serve

### Product Specifications

#### Construction:

Stainless steel housing and liner pan, 1" fiberglass insulation, 1" rubber legs.

#### Dimensions:

CW-1B: 10 5/8" H x 12 1/2" W x 12 1/2" D  
(27 cm x 32 cm x 32 cm)

CW-2Ai: 9 3/4" H x 14" W x 22" D  
(25 cm x 36 cm x 56 cm)

#### Electrical Information:

Each unit is equipped with a 60" three wire grounded power cord which terminates with a standard three pronged male plug. The 120V unit uses a NEMA 5-15 plug. The 240V unit uses a NEMA 6-15P 90° plug.

#### Electrical Specifications:

CW-1B: 120V, 800 W, 6.7 Amps  
240V, 800 W, 3.03 Amps

CW-2Ai: 120V, 1500 W, 12.5 Amps  
240V, 1600 W, 6.7 Amps  
208V, 1200 W, 5.8 Amps

#### CW-1B Options:

- 7 quart Adapter Plate (55707)
- 4 quart Adapter Plate (55704)

#### CW-2Ai Options:

- Two 7 quart Adapter Plates (14883)
- Three 4 quart Adapter Plates (14886)
- One 7 qt / One 11 qt Adapter Plate (14880)

#### Capacity:

CW-1B: 11 qt  
CW-2Ai: 22 qt

#### Shipping Information:

CW-1B: 16 Lbs (7.3 kg)  
CW-2Ai: 21 Lbs (13.3kg)  
Freight Class: 92 1/2  
FOB: Arizona, 85621

*\*APW Wyott Reserves the right to modify specifications or discontinue models without incurring obligation*