

# Carts & Kiosks - Utility Counter – Countertop Equipment Island

Contact Your Vollrath  
Sales Representative  
for Custom Carts  
& Kiosks!

**Standard:** Oversized laminated or polyform countertop with recessed area

**Standard:** Countertop grommets allow cord access for countertop appliances

**Standard:** 1" Boston bumper (black only) protects unit base

Item 75739 shown with modular options



**Standard:** Available in cost effective WCM (wood composite material) or lightweight ACM (aluminum composite material)

- Standard ACM carts are available in black, white, or silver
- Standard WCM carts are available in Harvest Cherry, Natural Maple, Castle Oak, or Black
- Matching toe kick



**WCM**  
Color Options

**Standard:** Open storage

Item 75739 shown with modular options



**Option:** Base color option

- Laminated base (ALL SIDES)
- Custom painted base

**Standard:** Heavy-duty paddle latch doors provide storage

**Standard:** Oversized indoor cart base with heavy-duty casters or adjustable leveling legs is mobile over uneven surfaces

#### Optional Features (Not Shown)

- Upgrade from laminated countertop to stainless steel
- Upgrade from laminated countertop to Corian
- Acrylic trash chutes
- 15 Amp electrical service (NEMA 5-15P)
- 30 Amp electrical service (NEMA L14-30P)
- 60 Amp electrical service (MENNEKES PLUG ME460P12W)
- 100 Amp electrical service (MENNEKES PLUG ME4100P12W)

For WCM (Wood Composite), carts add the letter "W" to the end of the model number. See Autoquotes for pricing information.



Setting  
the Standard™

For more details on ACM/WCM, visit [www.vollrathco.com](http://www.vollrathco.com)

# Carts & Kiosks - Utility Counter – Countertop Equipment Island

Utility Counter – Countertop Equipment Island — Dimensions shown in IN (CM)

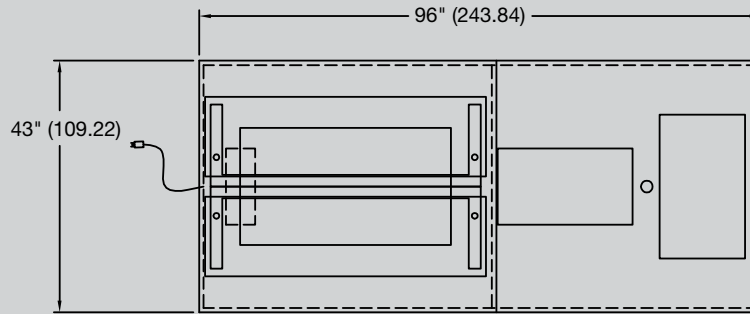

TOP VIEW

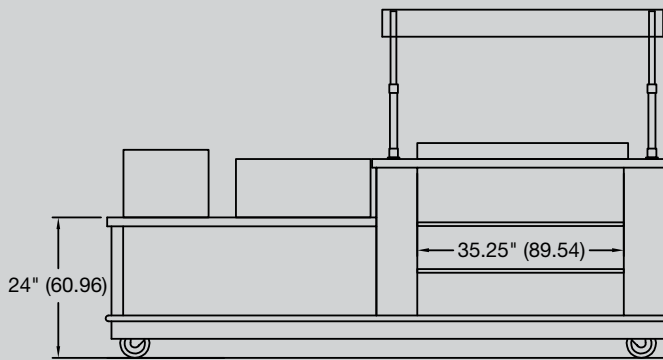

FRONT VIEW

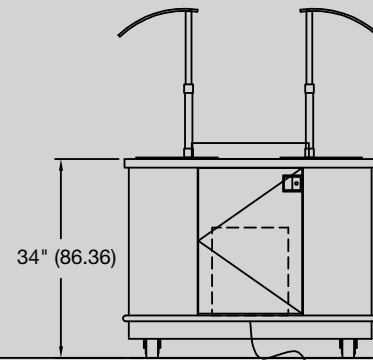

SIDE VIEW

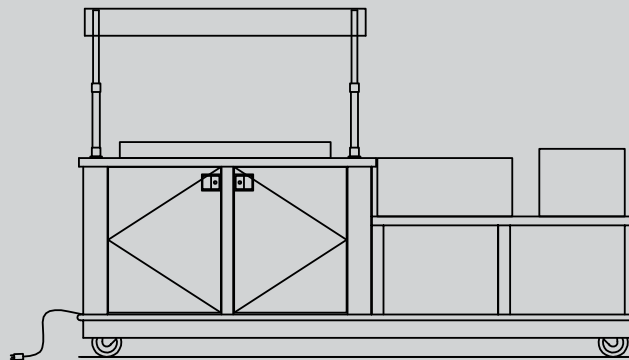

BACK VIEW

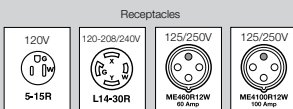

The Vollrath Company, L.L.C.  
 1236 North 18th Street  
 Sheboygan, WI 53081-3201 USA  
 Customer Service: 800.628.0830  
 Equipment Service: 800.628.0832  
 Main PH: 920.457.4851  
 Fax: 920.459.6573  
 Form L35773 Rev 7/10



Setting  
the Standard™