

AMERICAN RANGE

Quality Commercial Cooking Equipment

www.americanrange.com

ARHP HEAVY DUTY HOT PLATES

American Range ARHP series is design-engineered with safety, durability and convenience in mind, with heavy duty construction and uniquely designed top grates. These products will provide years of trouble free performance in the most demanding service operation. Uncompromising quality, performance and service at an affordable price.



ARHP



STANDARD FEATURES

- Stainless steel front and sides.
- Heavy gauge chassis.
- Two piece lift off burners, rated at 32,000 BTU/hr each.
- Individual S/S non clog pilots for instant ignition for each burner.
- 12"x12" sectional cast Iron top grates.
- Manual gas control valve for each burner.
- Optional 4" legs or equipment stands available.
- Removable drip pan for easy cleaning.
- Compact design for counter top use.
- AGA and CGA design certified, NSF Listed.
- One year limited warranty, parts and labor.

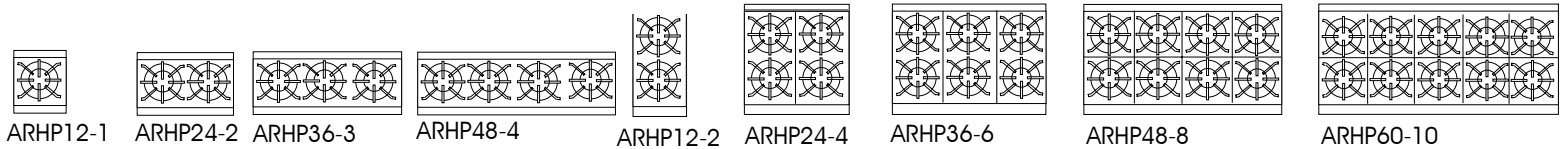
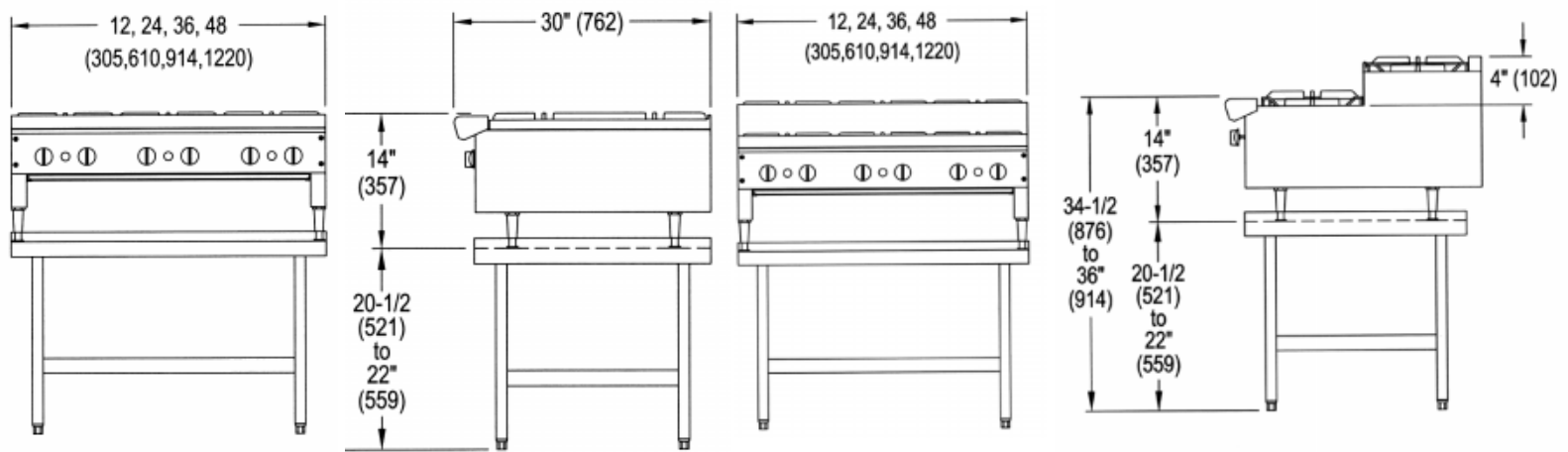

HEAVY DUTY HOT PLATES

MODEL	WIDTH	DEPTH	HEIGHT	BURNERS	TOTAL BTU	KW	SHIP. WT. Lbs.	Kg.
ARHP12-1	12"	18"	10"	1	32,000	9.37	51	23
ARHP12-2	12"	30"	10"	2	64,000	18.75	85	38
ARHP24-2	24"	18"	10"	2	64,000	18.75	85	38
ARHP24-4	24"	30"	10"	4	128,000	37.51	140	63
ARHP36-3	36"	18"	10"	3	96,000	28.13	115	52
ARHP36-6	36"	30"	10"	6	192,000	56.27	210	95
ARHP48-4	48"	18"	10"	4	128,000	37.75	140	63
ARHP48-8	48"	30"	10"	8	256,000	75.02	270	122
ARHP60-10	60"	30"	10"	10	320,000	93.78	325	147

STEP-UP HOT PLATES

MODEL	WIDTH	DEPTH	HEIGHT	BURNERS	TOTAL BTU	KW	SHIP. WT. Lbs.	Kg.
SUHP12-2	12"	30"	14"	2	32,000	9.37	85	38
SUHP24-4	24"	30"	14"	4	128,000	18.75	140	63
SUHP36-6	36"	30"	14"	6	192,000	18.75	210	95
SUHP48-8	48"	30"	14"	8	256,000	37.51	270	122

STANDARD FEATURES

- Heavy Stainless Steel Front and Sides.
- Heavy Gauge Chassis.
- Heavy duty 12" (305) x 12" (305) cast iron top grates, easily removable.
- Manual gas control valve for each burner.
- Stainless steel non-clog pilots for instant ignition on each burner.
- Full width removable crumb tray for easy cleaning.
- Die Cast, chrome plated control knobs.

- Easy cleaning removable lift of cast iron burner heads.
- 32,000 BTU/hr., highest in the industry.
- AGA and CGA Design Certified, NSF Listed. (step-up is NSF Listed only)
- One year limited warranty, parts and labor.

OPTIONS

- Saute and wok burners heads.
- S/S Wok ring available.

Gas: 5.0" W.C. Natural, 10.0" W.C. Propane. Specify type of gas and altitude if over 2000 feet. 3/4" NPT Gas inlet.

Clearances: From non-combustible walls, 0". When unit is placed next to combustible walls, clearances must exceed 12" (305) on sides, and 7" (179) from rear.

American Range Corporation is a quality manufacturer of commercial cooking equipment. Because of continuing product improvements these specifications are subject to change without prior notice.

